

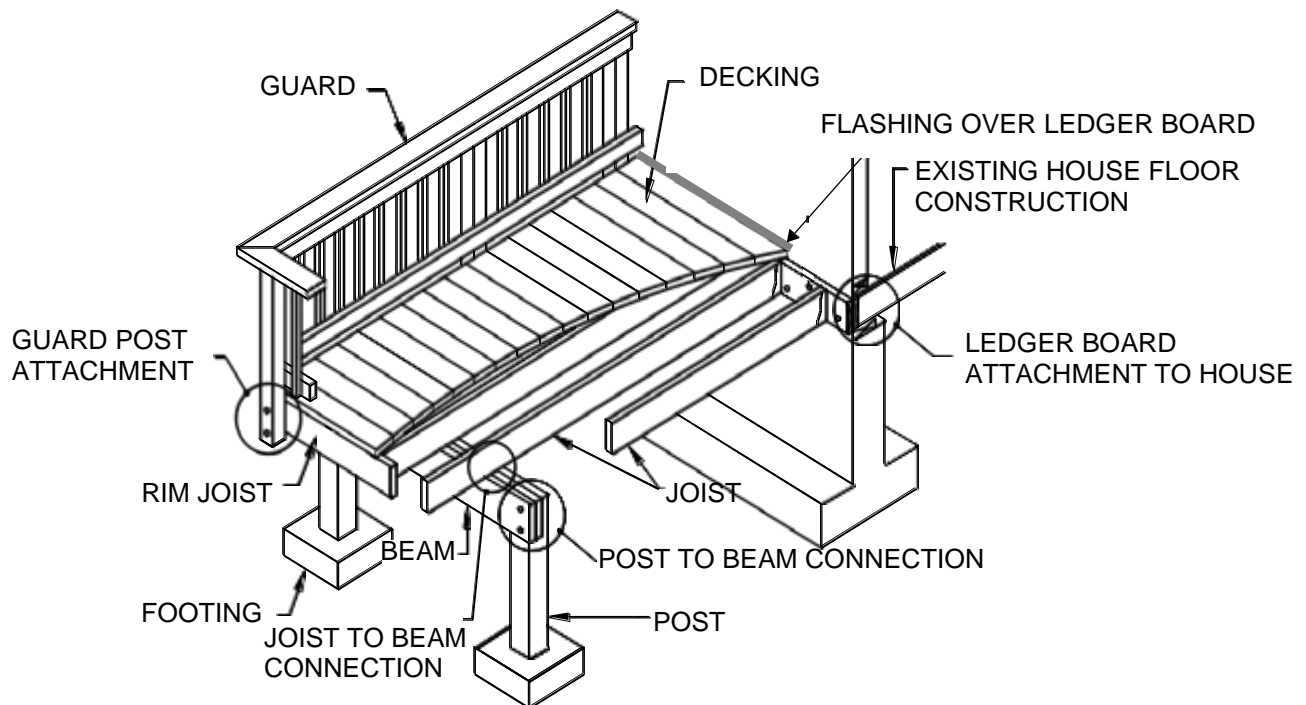

STANDARD RESIDENTIAL DECK DETAILS



This document may be used as a guideline only to assist in the preparation of your own construction drawings provided:

- ✓ **The proposed deck is for residential use only and is UNENCLOSED (No roof);**
- ✓ **No hot tubs, gazebos, or other roof structures are installed; and**
- ✓ **The deck construction conforms to these details.**

The information contained in this document is for references only. It is intended to assist homeowners with their deck project while ensuring compliance with the requirements of the Ontario Building Code. The drawings and details specified are typical construction details and other methods may be permitted either upon authorization from the Chief Building Official or by having the drawings sealed by a Professional Engineer or accompany a designer sheet signed for the category of Building Structural. All construction shall be inspected including footings (prior to placing concrete), framing and a final inspection prior to use.

All construction shall conform to the 2012 Ontario Building Code, as amended.

BUILDING PERMIT APPLICATION REQUIREMENTS

(To be completed by the Building Department)

| Description | | Required | Received | Comments |
|----------------|---|----------|----------|---|
| Applicable Law | Zoning By-Law Compliance | | | Comprehensive Zoning By-Law 2002-54, As Amended |
| | Ministry of Transportation (MTO) | | | Contact MTO: 519-372-4045 |
| | Owners Authorization letter | | | If the Owner is not the Applicant |
| | Permit Fee | | | \$150.00 |
| Forms | Building Permit Application | | | Via CloudPermit |
| | Schedule 1: Designer Information | House | | Note: House category required for qualified designer |
| Plans | Site Plan | | | Include septic bed and tank location, as well as an existing structure(s) – with measurements |
| | Deck Framing Plan | | | |
| | Exterior Elevations | | | |
| | Cross Section – including guards and connection to structures | | | |

F.Y.I.

Complete applications shall be submitted online via CloudPermit.

DECKS AND SEPTIC SYSTEMS

- Decks may not be constructed on septic systems
- A clearance distance of 5' (1.5m) is required from the deck pier to the septic tank in accordance with 8.2.1.6.A, Div. B, OBC
- A clearance distance of 16' (5m) is required from the deck pier to the closest distribution line in accordance with 8.2.1.6.B, Div. B, OBC.

JOISTS, BEAMS AND PIER SIZING

The Part 9 snow load for all decks within the Municipality of Northern Bruce Peninsula shall have a Specified Snow Load of 1.9kPa. If the live load will exceed 1.9kPa including hot tubs or drift loading it must be designed by a competent person (Professional Engineer).

JOIST SPAN

| Size | Spacing | Span |
|--------|---------|--------|
| 2 x 8 | 12" o/c | 12'-0" |
| | 16" o/c | 11'-0" |
| | 24" o/c | 10'-0" |
| 2 x 10 | 12" o/c | 14'-0" |
| | 16" o/c | 13'-0" |
| | 24" o/c | 12'-0" |
| 2 x 12 | 12" o/c | 16'-0" |
| | 16" o/c | 14'-0" |

Note: All lumber SPF or better - Solid blocking required if span exceeds 6'-11"

BEAM SPANS

| Joist span | Post Spacing | | | | |
|------------|--------------|------------|-------------------------|-------------------------|--------------------------|
| | 6'-0" | 8'-0" | 10'-0" | 12'-0" | 14'-0" |
| 6'-0" | 2 ply 2x8 | 2 ply 2x8 | 3 ply 2x8 | 3 ply 2x10 | 3 ply 2x12 4 ply 2x10 |
| 8'-0" | 2 ply 2x8 | 2 ply 2x8 | 3 ply 2x8 | 3 ply 2x10 | 3 ply 2x12 4 ply 2x10 |
| 10'-0" | 2 ply 2x8 | 3 ply 2x8 | 3 ply 2x8 | 3 ply 2x10 | 3 ply 2x12 4ply 2x10 |
| 12'-0" | 3 ply 2x8 | 3 ply 2x8 | 3 ply 2x10 4 ply 2x8 | 3 ply 2x10 | 3 ply 2x12 4ply 2x10 |
| 14'-0" | 3 ply 2x8 | 3 ply 2x10 | 3 ply 2x10 4 ply 2x8 | 3 ply 2x12 4ply 2x10 | 3 ply 2x12 4ply 2x10 |

FOOTING SIZES (Diameter in inches)

| Joist Span | Pier Spacing | | | |
|------------|--------------|-------|--------|--------|
| | 6'-0" | 8'-0" | 10'-0" | 12'-0" |
| 6'-0" | 10" | 10" | 14" | 14" |
| 8'-0" | 10" | 14" | 17" | 17" |
| 10'-0" | 14" | 14" | 17" | 17" |
| 12'-0" | 14" | 17" | 17" | 21" |

CONSTRUCTION DETAILS

BUILDING SECTION OF DECK CONSTRUCTION

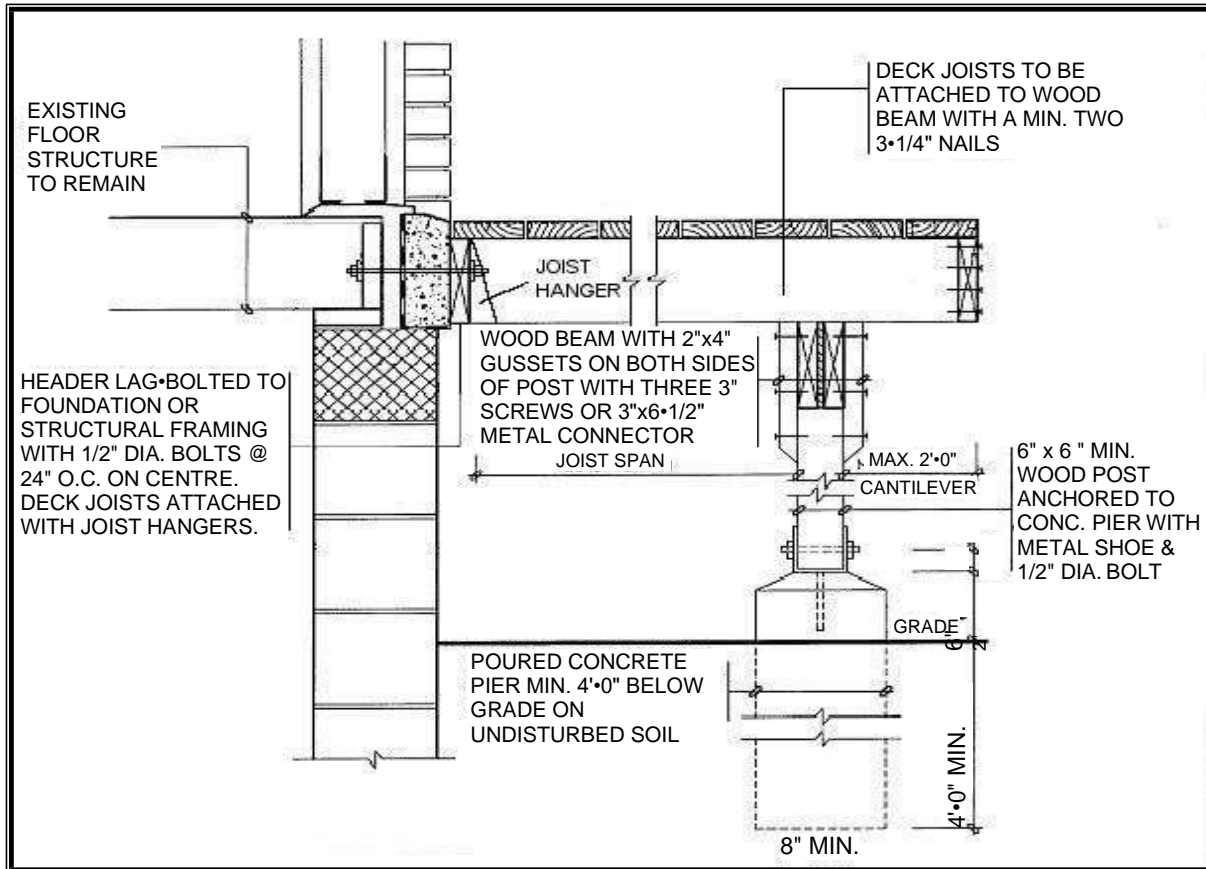

CONSTRUCTION NOTES:

- Maximum cantilever for joists and beams beyond supports is 24" (600mm).
- Typically, column pad footings or the use of pre-engineered concrete footing forms are required beneath the concrete pier unless an acceptable alternative is proposed.
- Footings/piers shall bear on undisturbed soil down a min. 48" (1.2m) below grade or directly on bedrock.

CONNECTION OF FLOOR JOISTS TO BEAM SUPPORT

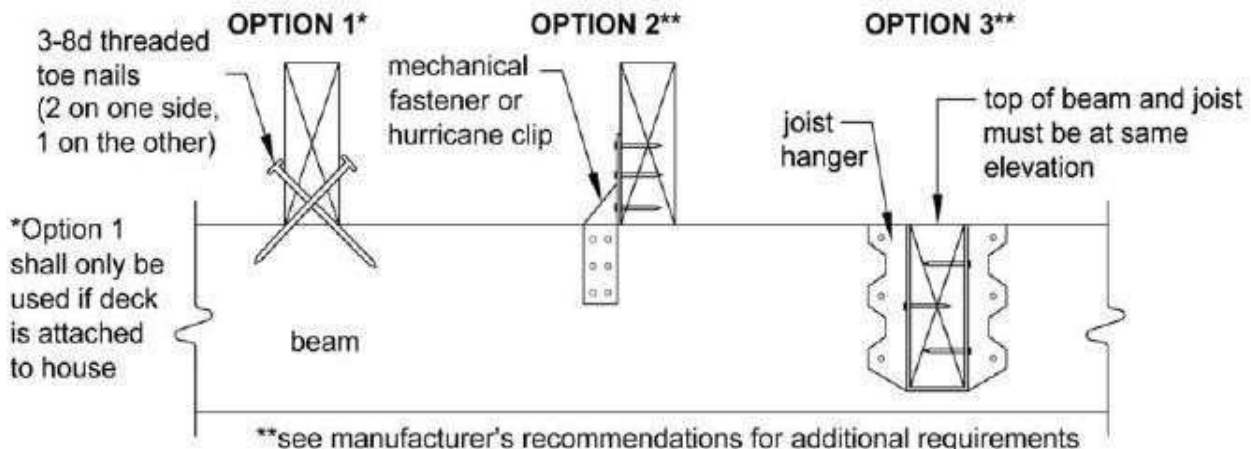

POST TO BEAM OPTIONS

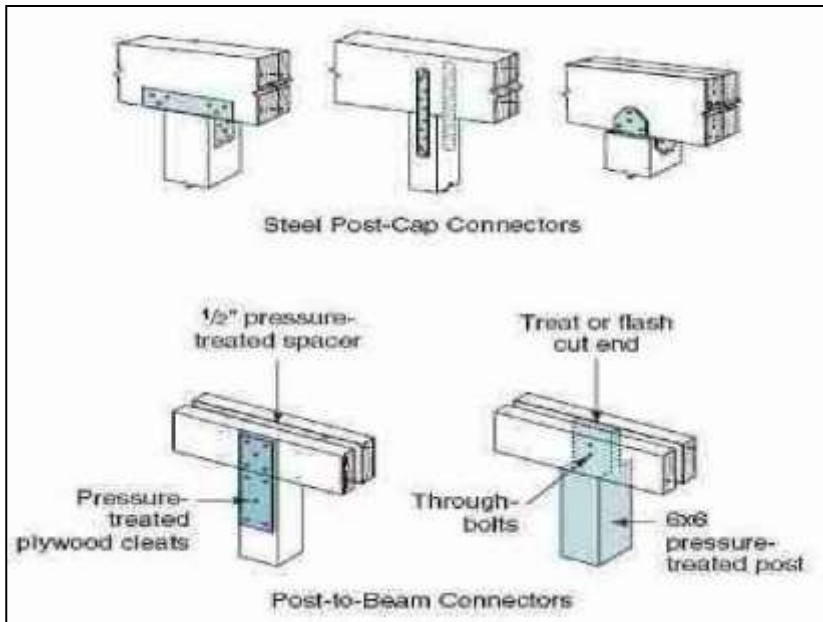

PROHIBITED CONNECTION
Beam to post

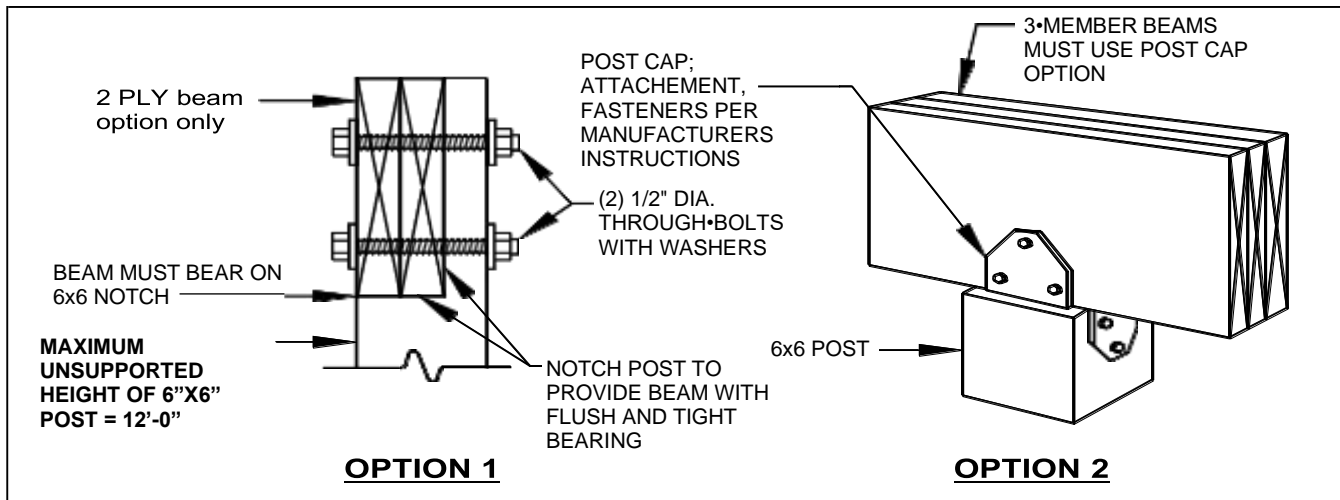
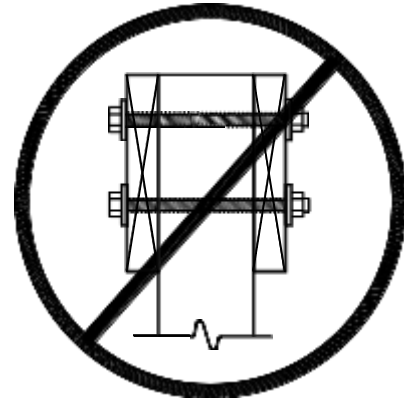

DETAIL FOR FRAMING AROUND A CHIMNEY OR BAY WINDOW

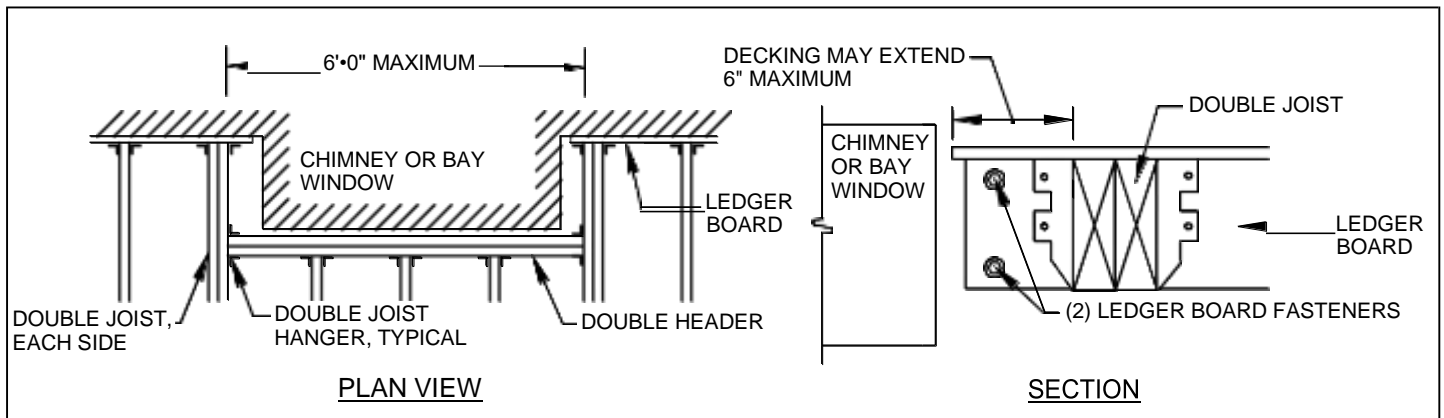

LEDGER BOARD ATTACHMENT

Decks are usually supported on one side by a ledger attached to the house. This ledger attachment is critical to ensure the deck is safely and securely supported to the house. There are very specific requirements that must be met. Follow the diagrams closely for the proper attachment of the ledger.

- The deck ledger shall NOT be nailed to the house - it must be lag screwed or bolted to the structure of the house.
- The size and spacing of the lag screws is based on their capacity. Lag screw values are assumed to be 325 pounds for 1/2-inch lag screws and 190 pounds for 3/8-inch lag screws. The span of the floor joists determines how much load is being transferred to the ledger and thus to the lag screws.

DECK LEDGER TO HOUSE ATTACHMENT – LAG BOLT SPACING (SEE DIAGRAMS)

| LAG BOLT SIZE | JOIST SPAN | | | |
|-----------------------------------|-----------------------------|---|---|--|
| | Up to 6' (1.8m) | 8' (2.4m) | 10' (3m) | 12' (3.6m) |
| 1/2" (12.7mm) | 32" o.c. (812mm) | 16" o.c. (400mm) | 16" o.c. (400mm) | 12" o.c. (300mm) |
| Equivalent 16" o.c. Joist Spacing | Every Other Joist Space | Every Joist Space | Every Joist Space | Each Joist Space with Two Every Other Space |
| 3/8" (9.5mm) | 24" o.c. (812mm) | 12" o.c. (300mm) | 12" o.c. (300mm) | 8" o.c. (200mm) |
| Equivalent 16" o.c. Joist Spacing | Two Every Third Joist Space | Each Joist Space with Two Every Other Space | Each Joist Space with Two Every Other Space | Two Each Joist Space Three Every Other Space |

- Deck ledgers shall be minimum 2x8 pressure-preservative-treated No. 2 grade lumber or other approved materials as determined by good engineering practices.
- When solid-sawn pressure-preservative-treated deck ledgers are attached to engineered wood products (structural composite lumber rim board or laminated veneer lumber), the ledger board attachment shall be designed in accordance with the manufacturer's recommendations or good engineering practices.
- Pilot holes shall be pre-drilled with a size between 17/32" to 9/16".

LEDGER BOARD FASTENER SPACING

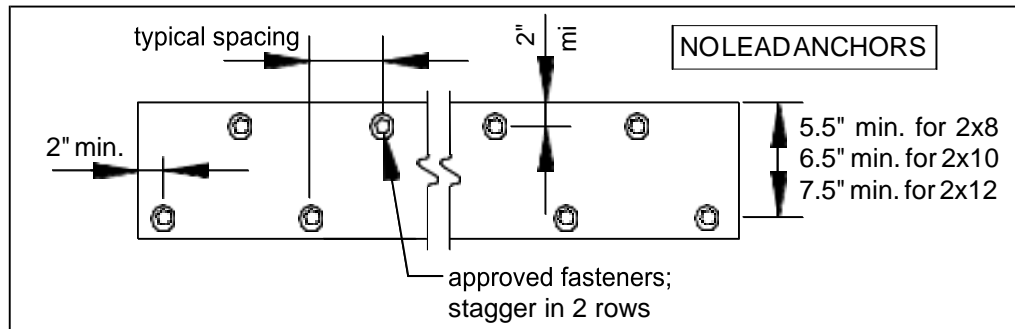

LEDGER BOARD CONNECTIONS

LEDGER BOARD CONNECTION TO RIM BOARD

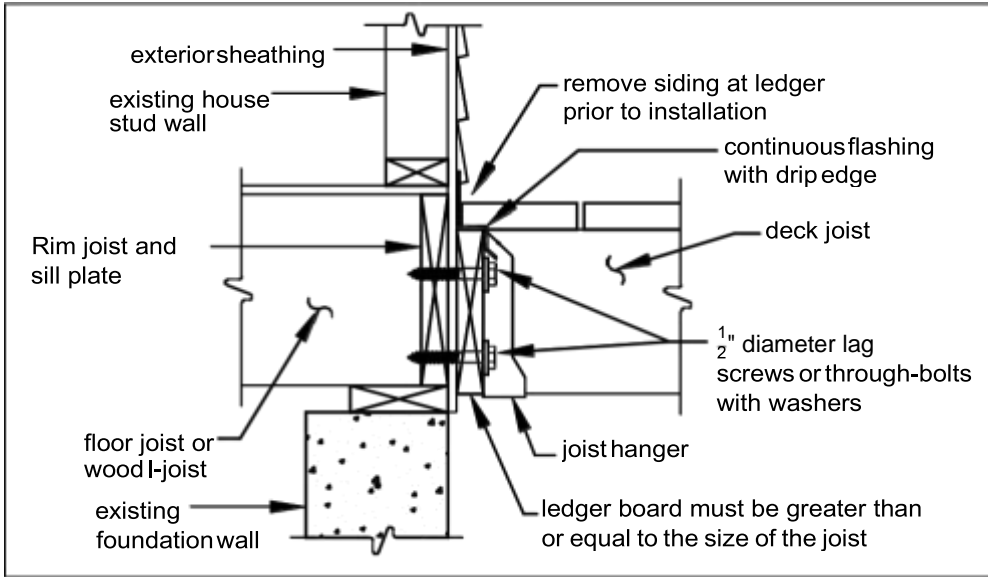

LEDGER BOARD CONNECTION TO POURED FOUNDATION WALL

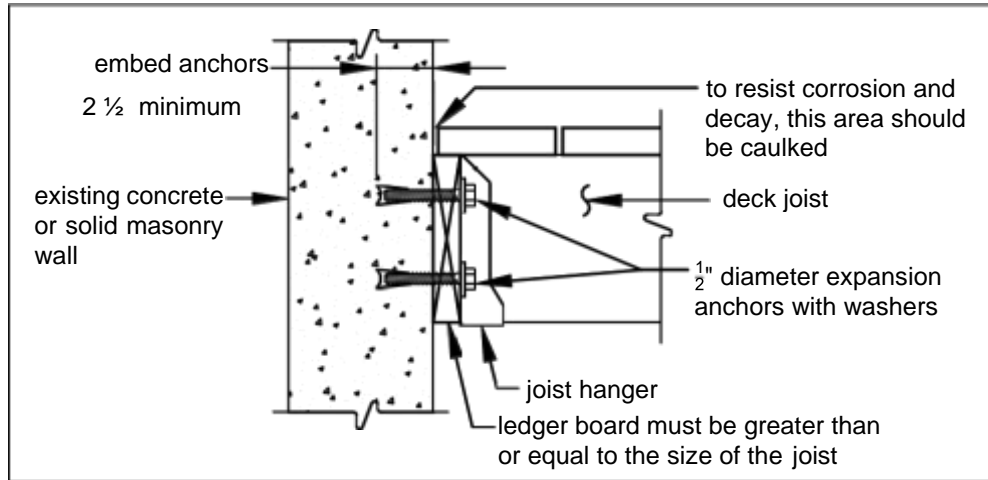

LEDGER BOARD CONNECTION TO BLOCK WALL

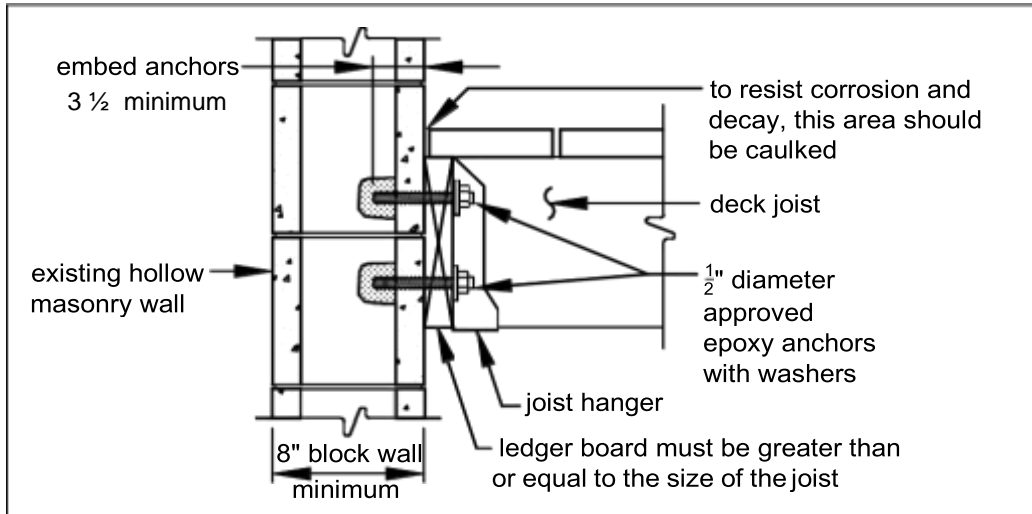

STRUCTURAL REQUIREMENTS

POST SIZING

DECK SUPPORT AND POST SIZING:

Minimum post size is 140mm X140mm (6"X6").

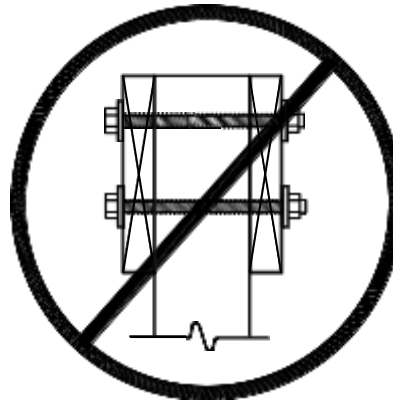

PROHIBITED CONNECTION

DECK ELEVATION PLAN AND DECK LATERAL SUPPORT – when deck exceeds 6'

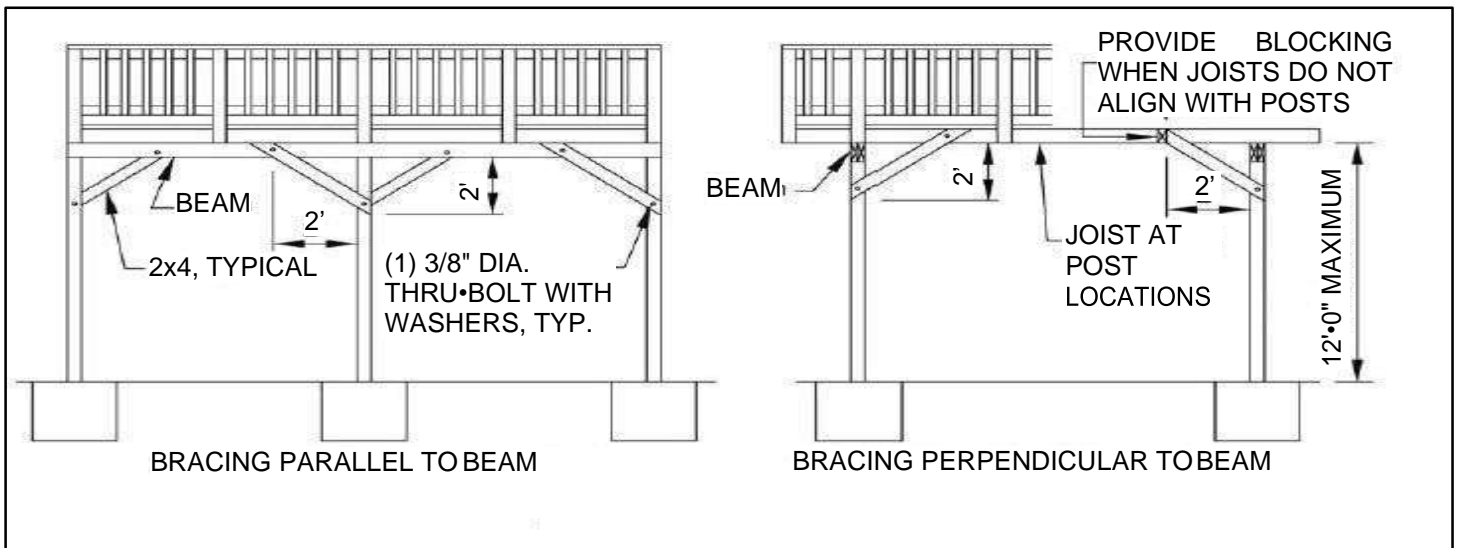

MINIMUM SIZE OF LOAD BEARING ELEMENTS – GUARDS (OBC SB-7 2.1.1):

| GUARD Element | Post | Top Rail | Bottom Rail | Picket / Baluster |
|--------------------------|-------------------------------|-------------------------------|-------------------------------|---------------------------------|
| Minimum size inches (mm) | 4" x 4" nominal (89mm x 89mm) | 2" x 4" nominal (38mm x 89mm) | 2" x 4" nominal (38mm x 89mm) | 1 9/32" x 1 9/32" (32mm x 32mm) |

MINIMUM SIZE OF FLOOR ELEMENTS (OBC SB-7 2.1.3):

| FLOOR Element | Minimum Size, in. (mm) |
|----------------------------|---|
| Dimensional lumber Decking | 5/4" x 6" nominal (25mm x 140mm) when each plank is fastened with 2 - 2 1/2" (63mm) nails |
| | 2" x 4" nominal (38mm x 89mm) when each plank is fastened with 2 – 3" (76mm) nails |
| Joists | 2" x 8" nominal (38mm x 184mm) |

GUARDS REQUIRED GUARDS

OPTION "A": POST AND RAIL SYSTEM

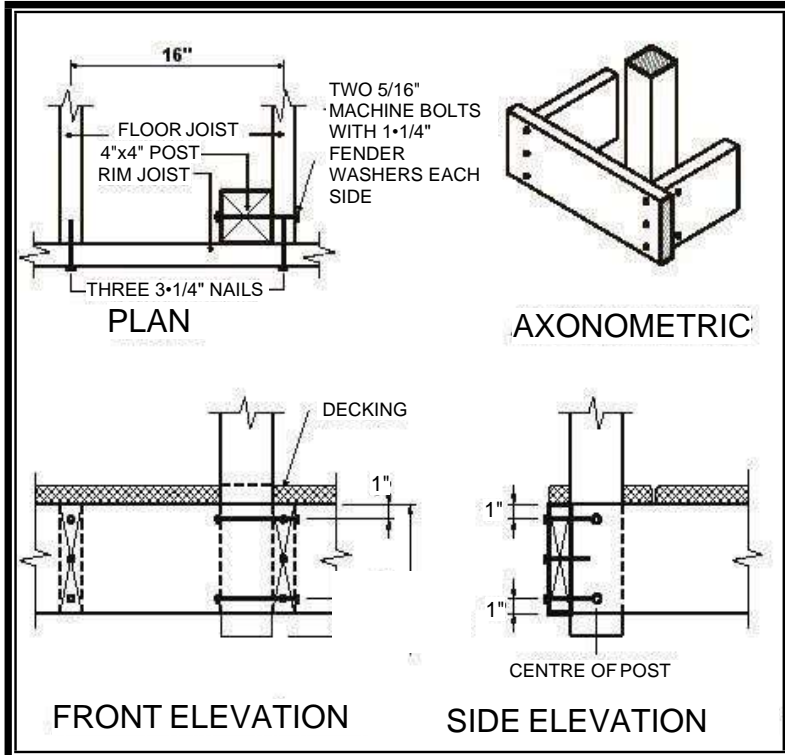

CONSTRUCTION NOTES

- Decking is omitted from the Post Detail plan view & axonometric view for clarity.
- Joists spaced max. 16" (400mm) O.C.
- Max. post spacing 3'-11" (1.2m)
- All fasteners shall be corrosion resistant
- All lumber shall be decay resistant and all cut ends of preservative treated lumber shall be treated to prevent decay.
- Min. height of guard where deck height is between 24" (600mm) & 5'-11" above grade: 35" (890mm).
- Min. height of guard where deck height exceeds 5'-11" (1.8m) above grade: 42" (1070mm).
- Maximum 4" opening between pickets.

SB-7 (Vol. 2 of the OBC) provides alternative details for the construction of guards.

POST AND RAIL CONNECTION / PICKET DETAILS

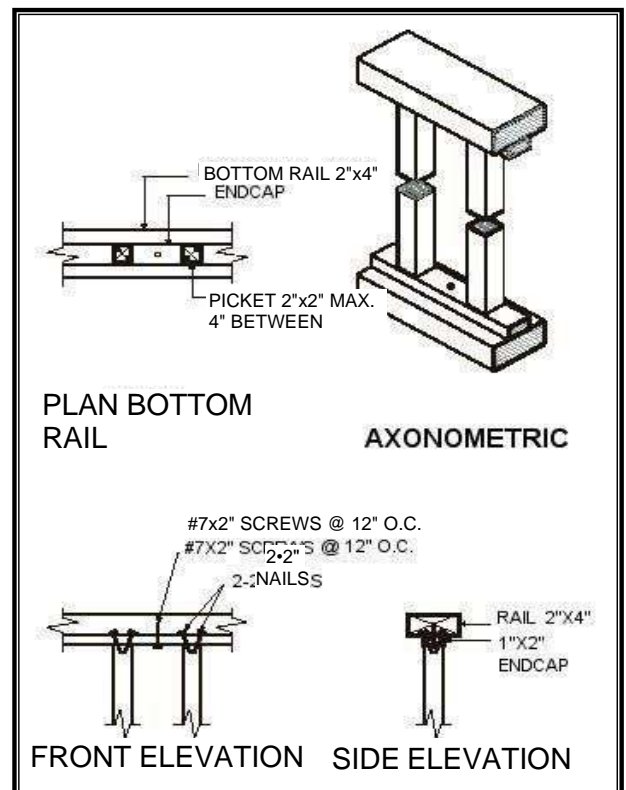
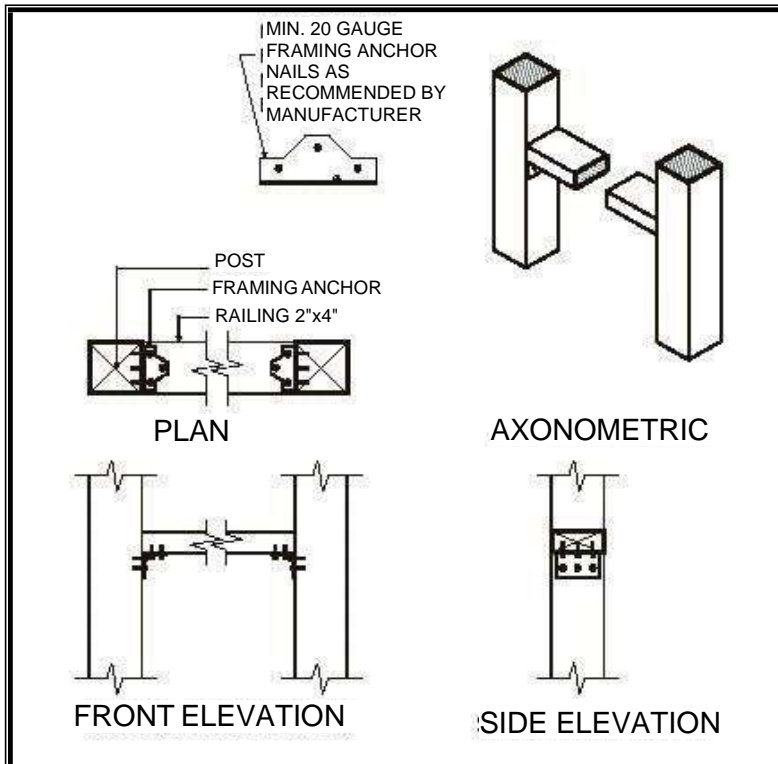

GUARDS

OPTION "B": CANTILEVERED PICKET SYSTEM

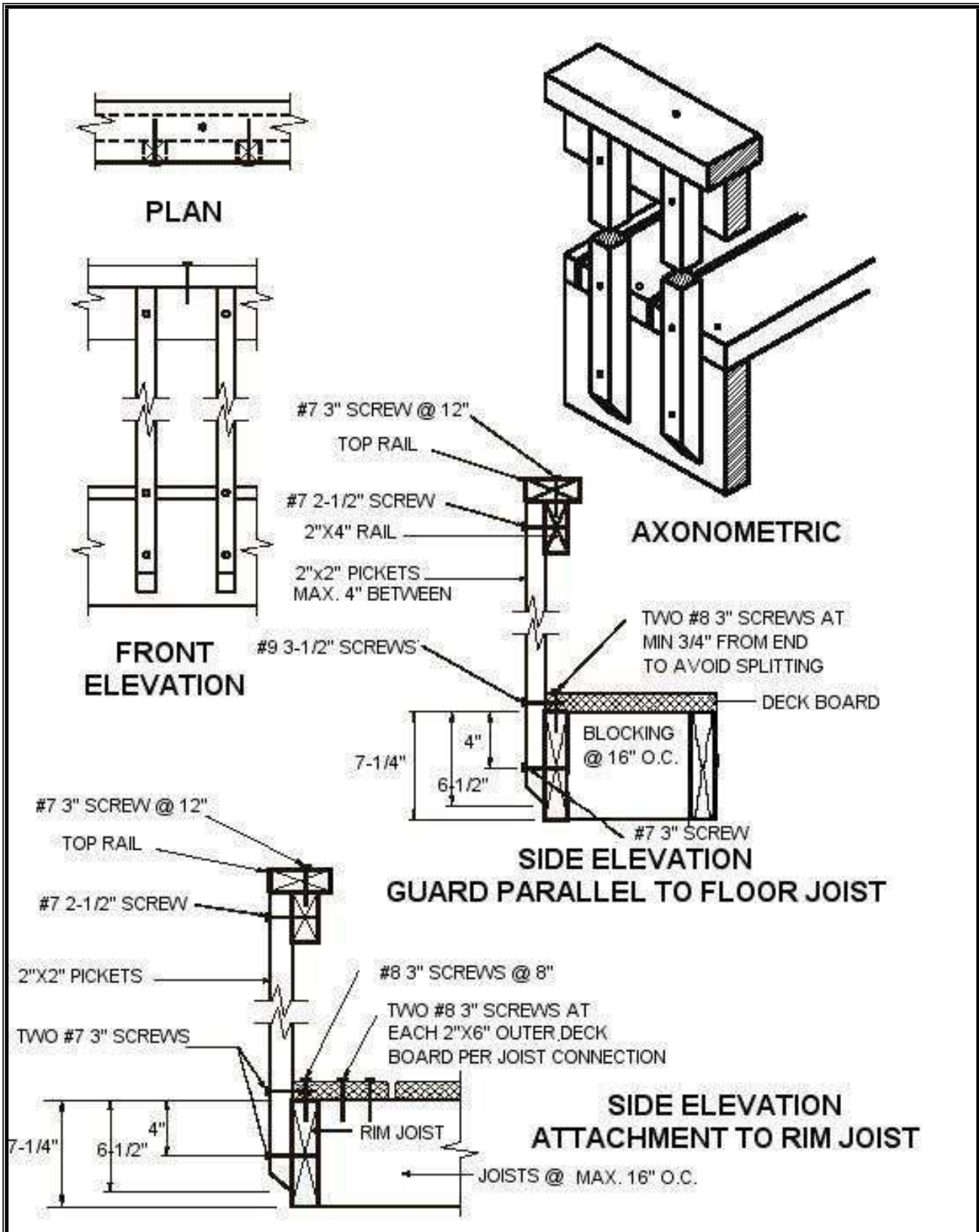

GUARDS

(Cantilevered Picket Continued)

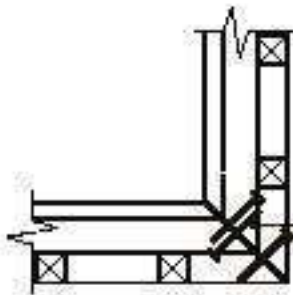

THREE #8x3" SCREWS

PLAN TOP RAIL

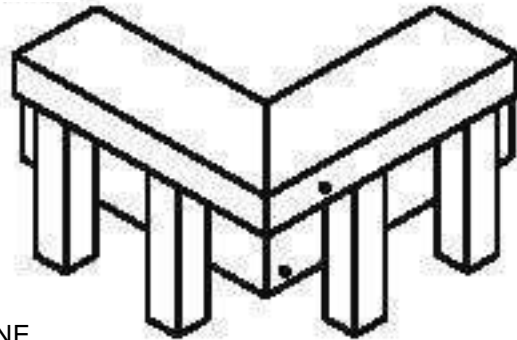

AXONOMETRIC

NOTE:

1. TWO #8x3" SCREWS INTO 2"x4" RAIL AND ONE #8x3" SCREW INTO TOP RAIL
2. PROVIDED A MINIMUM OF 10 PICKETS BEYOND THE RETURN IF END RESTRAINT OF THE GUARD IS PROVIDED BY THIS RETURN DETAIL ONLY

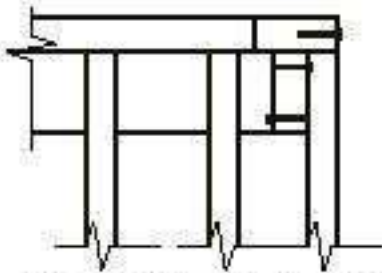

FRONT TOP RAIL

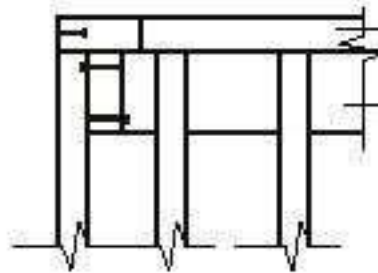

SIDE TOP RAIL

TOP RAIL

2"x4" RAIL

CONSTRUCTION NOTES:

- All fasteners shall be resistant to corrosion.
- All lumber shall be decay resistant. All cut ends of preservative treated lumber shall be treated to prevent decay.
- Composite decking is required to have BMEC or CCMC approvals
- Pre-engineered guard systems are required to have Ontario Engineering
- Any guard assembly that is site manufactured, such as wood/glass guards is required to be engineered
- A privacy wall/ fence boards is permitted if constructed as a guard and should be discussed with Building Inspector prior to constructing

STAIR DETAILS

HANDRAIL and STAIR CONNECTIONS

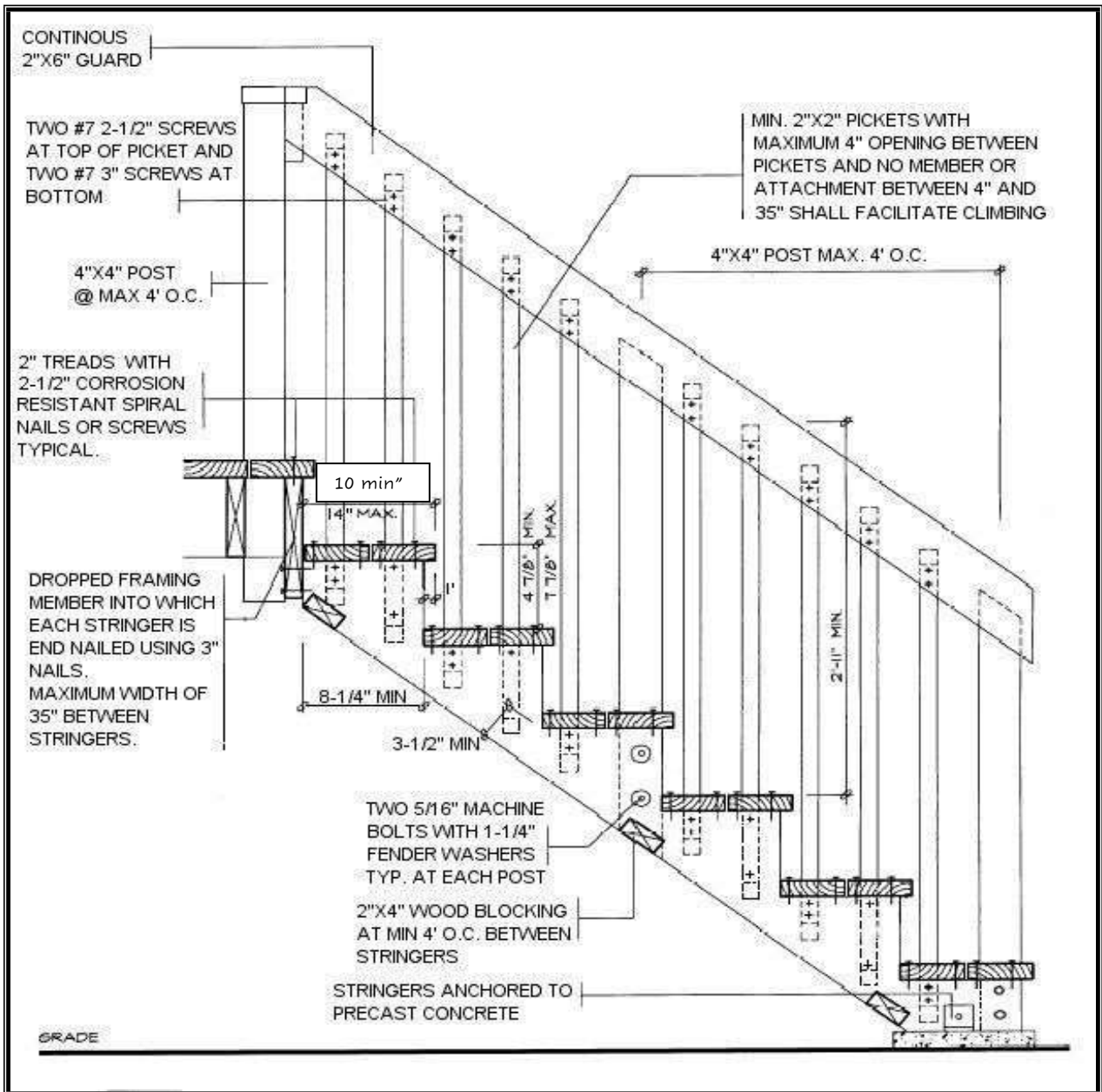

CONSTRUCTION NOTES:

- Handrails are required to be installed on every stair with more than 3 risers. Provide a guard on both sides of stair where required as indicated.
- Height of handrails (where guards not required) on stairs shall be between 34" (865mm), and 42" (1070mm).
- Height of guard for a deck between 24" (600mm) and 5'-11" (1.8m) above grade is 36" (900mm) Height of guard for a deck more than 5'-11" (1.8m) above grade is 42" (1070mm)
- Maximum 4" openings between pickets and no member or attachment shall facilitate climbing
- All steps to be equal rise and run between landings.